

## FACT SHEET

### ● Modular Olfactometer OL025

The modular olfactometer OL025 is a device for generating precise and reproducible olfactory or pain stimuli in the nose, without tactile or thermal stimulation. The rise time of the stimulus is fast enough to allow the recording of olfactory evoked potentials (OEP).

The integration of intelligent electronics greatly simplifies the use of the OL025.

The control software make operation intuitive and easy. A USB port serves as a connection between PC and olfactometer.



**OL025 (OM16B) fully equipped.**

The modular design allows the customer to start with a simple version (OM2) to later expand the olfactometer step by step.

The base of the olfactometer can be equipped with a water heating system module, vacuum pump module and a pressure pump module. All units are housed with sound-absorbing material to minimise noise pollution.

The configuration can be adjusted to the customer's needs, e.g., if inhouse pressure is available, a pump module is not necessary. This can significantly lower price of the device.

The air treatment system allows a long use of the olfactometer without exchanging drying components. These air-drying and air-cleaning cartridges can be replaced quickly and easily. A humidity sensor alarms the user if the drying material is getting saturated.

An air purification cartridge is integrated in the exhaust line to prevent possible contamination of the room. This system only works with saturated air and NOT with gases like CO<sub>2</sub> and H<sub>2</sub>S. If gases are used, room ventilation is necessary.

The OL025 can pass on information to existing EEG systems (modifications may be necessary) or the Burghart OL026 EEG System. Alternatively, the olfactometer can be triggered externally or the olfactometer can trigger an external device.

The system can be operated on a regular 230V/16A socket or on 110V/30A.

## The modular system

The idea of the modular OL025 olfactometer is the division of the components into individual components to allow our customer to create the Olfactometer exactly to their needs.

## Cartridge modules

The cartridge modules are easy to change and to clean. Different cartridges are available depending on the purpose. Generally, they serve as containers of the water, for control and dilution, as well as for the odours. Each module is individually surrounded by warming water to ensure a constant surface temperature.

4 different cartridges are available:

- **Cartridge large** (for liquids from 20 – 50ml) **(A)**
- **Cartridge small** (for liquids from 5 – 15ml) **(B)**
- **Cartridge textile** (designed for solids and textiles) **(C)**
- **Cartridge pads** (designed with filter pads with up to 4 layers for droplets of liquids) **(D)**

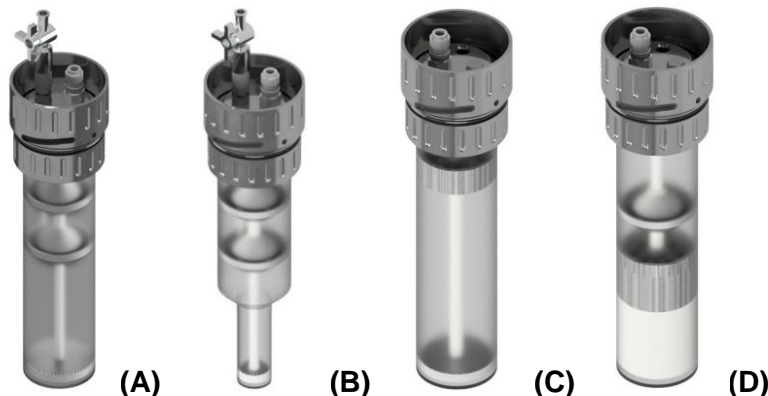

## Flow modules

The rack can be equipped with the following modules:

- **Flow module (XX lpm)**

- The XX stands for a variable flow rate which is selectable by the customer. The default flowrate is 10 Liter per minute.
- This flow module contains a mass flow controller (MFC). Due to the high flexible system this MFC can be replaced by every other flow range on request (e.g., 4 lpm)
- Advanced software allows the usage of multiple gases with one MFC.
- The module can either be used per channel (in case mixing is on focus) or in combination with a Switch module to serve up to 4 odorant channels.

- **MET Module (XX lpm)**

- This flow module contains a mass flow controller (MFC), which has a flow rate of 12 lpm as standard. If desired, this MFC can be replaced by any other flow range (e.g., 4 lpm). It is responsible for the suction (negative flow) and is part of the basic equipment of the OL025.
- This module is the heart of the “Burghart fast switching principle”.

- **Switch module**

- The module contains a valve array and allows an inexpensive option to expand odorant channels.
- Two different operations are possible:
  - Switch module in flow module inlet: Up to 4 gases can be hooked up and independently distributed to the MFC. A mixing of these gases is not possible. The gases can then be selected by software.
  - Switch module in flow module outlet: Up to 4 odorant channels can be supplied by one MFC. No mixing possible.
- If no mixing is considered, this option avoids the selection of 3 additional flow modules.

## Connection hose

The diameter of the olfactometer head is 65mm. The bending radius of the hose is 70mm. By simply dismantling the hose head, it is possible to feed the hose through a 50 mm diameter hole. This feature is particularly interesting for use in MRI or fMRI!

The standard connection hose is designed to deliver 8 different odorants to the patient’s nostril. For birhinal applications, two connection hoses are necessary.

Burghart offers customized hose lengths from 3 to 15m meters. The most selected lengths are 3 m for EEG examinations and 12 m for fMRI application.

A long hose (longer than 3 m) cannot be used for fast EEG recording.

To avoid recording artefacts during fMRI examinations, the head of the connection hose is made of non-ferromagnetic materials.

## Minimum standard setting of an OL025

4x flow module 10lpm (Control, Dilution, Odorant 1 and Odorant 2), 1x MET module 12lpm.

## Software

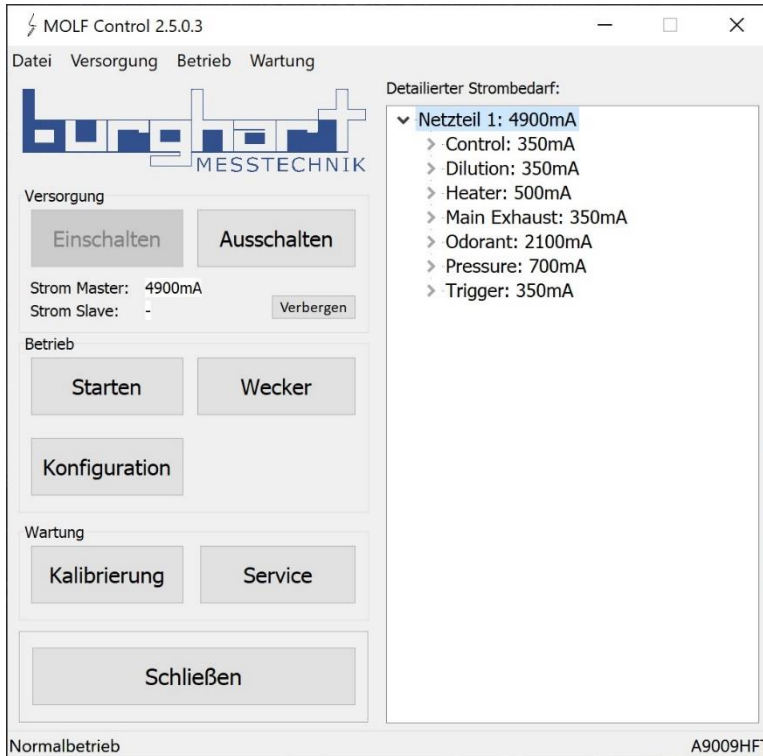

The olfactometer is operated via its own software (MolfControl). Dialogue-guided standard procedures support the user in the proper use of the programme. This improves usability and ensures intuitive operation.

The software supports German and English language.

## The class editor

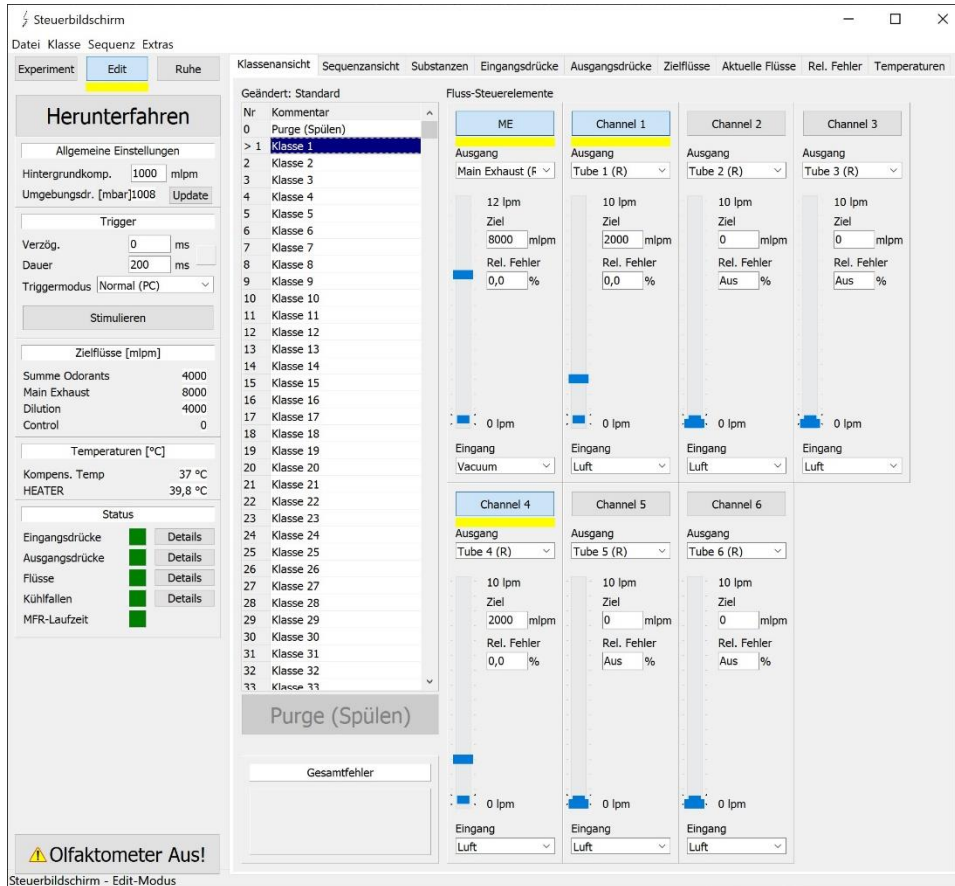

The user interface of the class editor (setting of flows and concentrations) is designed for intuitive operation. Flows can be set and saved comfortably.

This works class by class. I.e. a wide variety of flow settings, with a wide variety of concentrations of the odour or gas, are assigned to individual classes.

It is also possible to mix up to 6 different odorants (depending on the olfactometer configuration).

The stored classes are used for the sequence of your experiment.

## The sequence

Steuerbildschirm - Sequenz läuft

Once your classes (types of stimuli) are defined, you can set the order in which they are presented to the subject, and the timing for each stimulus in a sequence.

Once a sequence has been created, it can be saved and reloaded at any time. This gives you the possibility to quickly repeat an already created experiment under the same conditions as soon as the OL023 is ready for use.

## The Purge-System

To avoid wasting odour during the ISI (inter-stimulus interval), the software has a purge function. During the ISI, the odorant flow is switched off and replaced by a higher flow of pure air. The start and offset of this purge time can be set in the sequence table.

## The guided device start-up

A standard start-up procedure has been implemented which prompts the user to perform various tests to ensure that the OL023 is operating correctly and that the test results obtained are usable. These tests include a pressure input test, a leak test and a water heating test.

## Device Safety

The olfactometer is equipped with a variety of safety features to prevent damage to the unit and injury to patients. On demand the control screen of the olfactometer shows possible faults and malfunctions. This helps to identify and rectify faults.

## Technical Data

### General Data

Device name and type      Modular Olfactometer OL025

### Mechanical Data

Overall weight (OM16b without water)      max. 400kg  
Overall width      1.36m plus connection hose  
Overall depth      0.78m  
Overall height (basic rack)      1.4m  
Protection class      IP 21

### Electrical Data

Mains power connection      Europe: 230 VAC, 50-60Hz  
USA: NEMA5-30 or NEMAL5-30 (needed to be supplied by customer)

Peak power consumption      3500VA

### Computer (not included)

Minimal hardware requirements      PC or laptop with USB-port,  
4GB RAM minimum, 8GB or more recommended,  
Dual core processor minimum, 4 cores or more recommended

Operating system      Microsoft Windows 10™ English or German  
Screen resolution      Minimum of 1280x1024, 32 bit colour depth  
(Scaling affects resolution)

### Additional Continuous Supply and Waste Requirements

Compressed air supply OM8b      max. 60 litres / minute clean, breathable air  
(only if external pressure is used)      at 3 to 12 bar (44 to 174 psi)

Exhaust duct (passive or active) OM8b      approx. 40 litres per minute odorant waste  
(only if gases like CO<sub>2</sub> or H<sub>2</sub>S are used)

Stimulation gases (if desired)      up to 8 litres / minute at 1.6 to 2.0 bar  
(23 to 29 psi)

### Ranges and Precision

Temperature measurement:      1.0 to 49.0 °C +/- 1 °C  
Input pressure measurement:      0 to 3000 mbar +/- 20 mbar  
Output pressure measurement:      0 to 1000 mbar +/- 5 mbar  
Atmospheric pressure measurement:      800 to 1100 mbar +/- 2 mbar  
Volume flows (standard range)      0.4 to 10 lpm +/- 2%

### Ambient Conditions

Temperature during operation      +10°C to +40°C  
Temperature during storage      5°C to +40°C  
Rel. humidity during operation      10% to 75% (non-condensing)  
Rel. humidity during storage      10% to 80% (non-condensing)  
Operation and storage without frost, dew, dripping water, rain or direct sunlight.